



SHURflo®

9325 SERIES

12/24 VDC POWERED

SUBMERSIBLE PUMP

OWNERS MANUAL

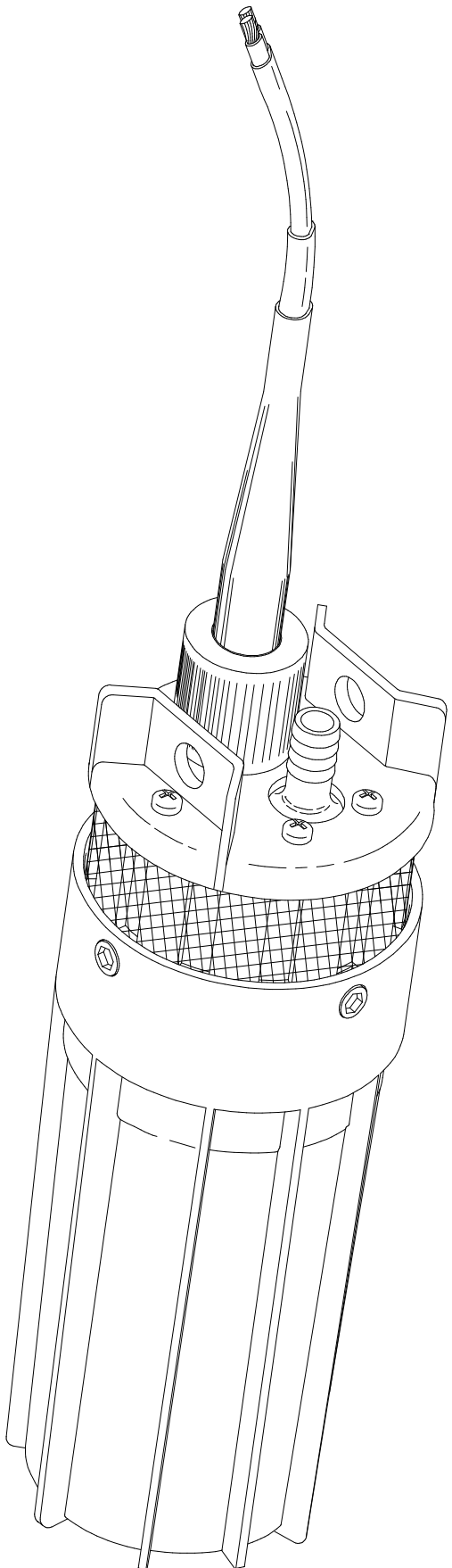

WARNING



DO NOT use any SHURflo pump for petrol/gasoline, petroleum products, solvents, thinners or ANY other flammable liquid with flash point below 180°F [82°C].
NOT FOR USE where flammable vapors are present.

Note:

BEFORE CONNECTING OR OPERATING THIS PRODUCT, PLEASE READ THESE INSTRUCTIONS COMPLETELY.

TABLE OF CONTENTS

| | PAGE |
|--|-------------|
| INTRODUCTION | 2 |
| TOOLS REQUIRED FOR INSTALLATION & MAINTENANCE | 2 |
| COMPONENTS NEEDED FOR INSTALLATION | 2 |
| APPLICATION WORKSHEET and FLOW TABLES | 3 |
| PUMP CONNECTIONS & INSTALLATION INSTRUCTIONS | 5 |
| TROUBLESHOOTING | 8 |
| PUMP REMOVAL and DISASSEMBLY | 9 |
| PUMP RE-ASSEMBLY | 11 |
| TECHNICAL SPECIFICATIONS | 14 |
| PARTS LIST and REPLACEMENT PART KITS | 15 |
| SUBMERSIBLE PUMP ASSEMBLY DRAWING | 16 |
| WARRANTY | 17 |

INTRODUCTION

This manual has been provided as an aid to the operator with information about installing, operating, and servicing of the SHURflo 9325 Series Submersible Pump. The engineers and technicians who designed and manufactured these pumps have developed these instructions from their experiences.

These instructions should be read completely before installing your new pump. Keep this manual readily available at all times for use when installing, operating, or servicing your pump.

For proper placement in the well refer to the application worksheet on pages 3-4.

This pump is not to be used with flammable liquids.

TOOLS REQUIRED FOR INSTALLATION & MAINTENANCE

| | |
|--------------------------------|---|
| #1 and #2 Phillips Screwdriver | Wire Cutters |
| 5/64" Allen Wrench | Wire Strippers |
| 5/32" Allen Wrench | Pliers |
| 3/16" Allen Wrench | Dry Cloth or Cotton Tipped Applicator for cleaning O-Ring grooves |
| Electrical Tape | Tie wraps |

COMPONENTS NEEDED FOR INSTALLATION

APPLICATION WORKSHEET

POWER CABLE (Not Included)

COUPLER AND DISCHARGE FOR OUTLET (Included)

DISCHARGE HOSE OR PIPE (Not Included)

SAFETY LINE (Not Included)

POWER SUPPLY (Not Included)

FUSE (Not Included)

CONTROLLER (Not Included) Use a Linear Current Booster for optimum performance

APPLICATION WORKSHEET

Please fill in for your records.

MODEL NUMBER _____
 SERIAL NUMBER _____
 MFG. DATE _____
 PURCHASE DATE _____
 TOTAL WELL DEPTH _____ FT(M)
 WELL RECOVERY RATE _____

PUMP DISTRIBUTOR:

Name _____
 Address _____
 City _____
 Phone _____

SOLAR ARRAY INFORMATION:

MAKE/MODEL _____
 WATTS AVAILABLE (NO. OF PANELS X WATTS PER PANEL =) _____

CONTROLLER INFORMATION:

MAKE/MODEL _____

NOTE: Use of an LCB (Linear Current Booster) Unit is required for optimum performance. LCB is not included.

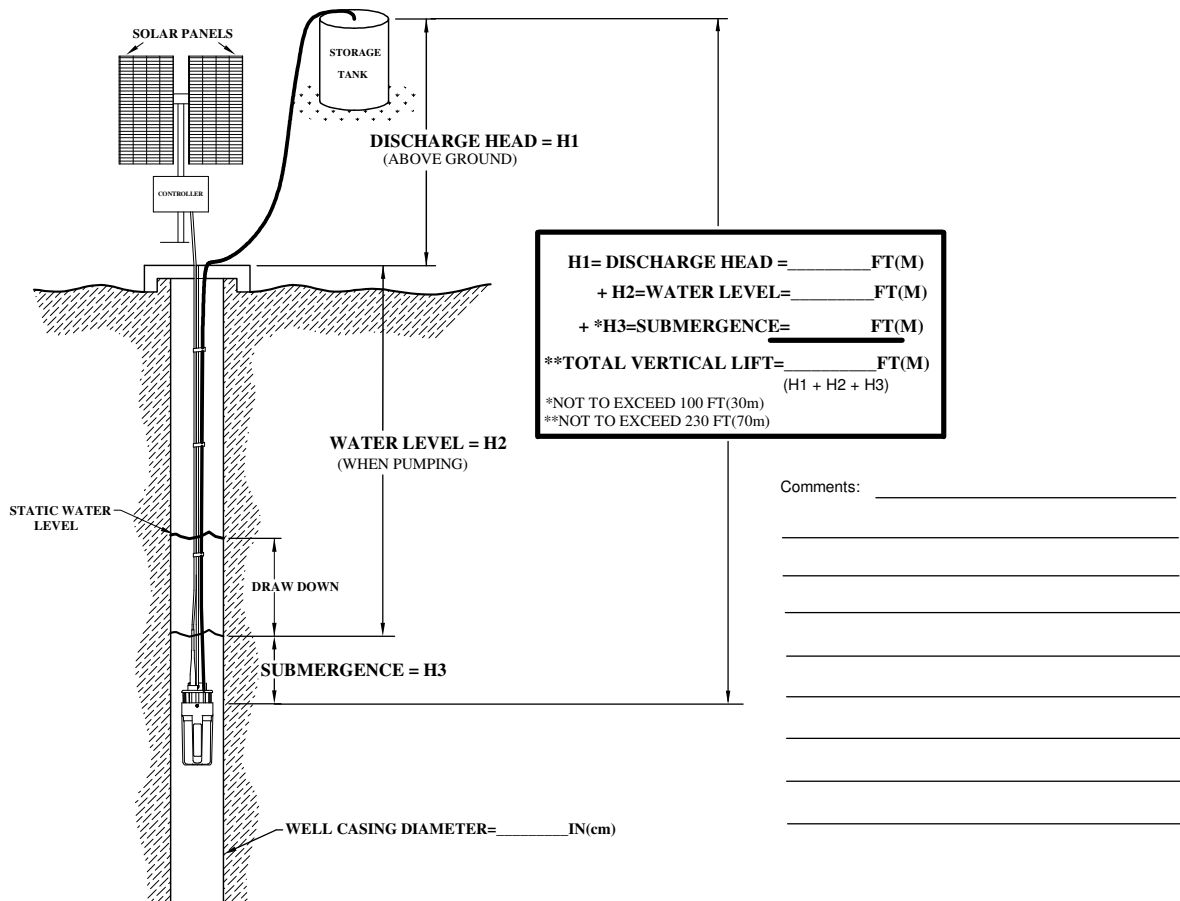

TERMS:

H1=DISCHARGE HEAD = Vertical distance in feet from ground level to level of water in elevated storage tank.

H2=WATER LEVEL = Vertical distance in feet from level of water in well when pumping up to ground level.

H3=SUBMERGENCE = Vertical distance in feet from level of water in well when pumping, to pump position in well.

Note: **DO NOT** submerge the pump deeper than necessary unless the water level is known to be highly variable (Pump may operate dry for short periods of time.).

Drawdown = Vertical distance in feet from static water level to water level when pumping.

Note: Make sure the pump is installed below the lowest anticipated water level. Consider the seasonal changes in the region.

PUMP FLOW TABLES - TOTAL VERTICAL LIFT= H1+H2+H3

12 VDC FLOW TABLE

| TOTAL VERTICAL LIFT | | FLOW RATE PER HOUR | | SOLAR ARRAY SIZE MINIMUM TOTAL POWER RATING | CURRENT AMPS |
|---------------------|--------|--------------------|-----|---|--------------|
| FEET | METERS | GAL | LTR | WATTS | |
| 20 | 6.1 | 56 | 212 | 22 | 1.2 |
| 40 | 12.2 | 54 | 204 | 28 | 1.5 |
| 60 | 18.3 | 52 | 197 | 33 | 1.8 |
| 80 | 24.4 | 50 | 189 | 37 | 2.0 |
| 100 | 30.5 | 49 | 186 | 40 | 2.1 |
| 120 | 36.6 | 47 | 178 | 45 | 2.4 |
| 140 | 42.7 | 46 | 174 | 51 | 2.7 |
| 160 | 48.8 | 44 | 166 | 56 | 3.0 |
| 180 | 54.9 | 43 | 163 | 61 | 3.3 |
| 200 | 61.0 | 41 | 155 | 64 | 3.4 |
| 230 | 70.1 | 36 | 136 | 72 | 3.9 |

24 VDC FLOW TABLE

| TOTAL VERTICAL LIFT | | FLOW RATE PER HOUR | | SOLAR ARRAY SIZE MINIMUM TOTAL POWER RATING | CURRENT AMPS |
|---------------------|--------|--------------------|-----|---|--------------|
| FEET | METERS | GAL | LTR | WATTS | |
| 20 | 6.1 | 117 | 443 | 58 | 1.5 |
| 40 | 12.2 | 114 | 432 | 65 | 1.7 |
| 60 | 18.3 | 109 | 413 | 78 | 2.1 |
| 80 | 24.4 | 106 | 401 | 89 | 2.4 |
| 100 | 30.5 | 103 | 390 | 99 | 2.6 |
| 120 | 36.6 | 101 | 382 | 104 | 2.8 |
| 140 | 42.7 | 99 | 375 | 115 | 3.1 |
| 160 | 48.8 | 98 | 371 | 123 | 3.3 |
| 180 | 54.9 | 93 | 352 | 135 | 3.6 |
| 200 | 61.0 | 91 | 345 | 141 | 3.8 |
| 230 | 70.1 | 82 | 310 | 155 | 4.1 |

I. PUMP CONNECTION & INSTALLATION INSTRUCTIONS

WARNING: IMPROPER INSTALLATION WILL VOID WARRANTY.

1. Select and Purchase the Proper Jacketed Cable (Fig. 1)

Note: **DO NOT** select cables with irregular shapes, rough or grooved surfaces. A smooth jacket is needed for proper sealing.
Use a #10 AWG jacketed Submersible Cable that fits into the general size requirements shown (Fig 1).

| RECOMMENDED CABLE TYPE | MINIMUM DIMENSION OF CABLE | MAXIMUM DIMENSION OF CABLE |
|------------------------|----------------------------|----------------------------|
| FLAT PARALLEL | | |
| | | |

FIGURE 1

2. Assemble Cable Boot (Fig. 2 thru 7)

- 2.1 Strip the outer cable jacket (A) 2.0 in. [5 cm] (Fig. 2).
- 2.2 Cut one of the lead wires 1.0 in. [2.5 cm] (Fig. 3).
- 2.3 Wrap electrical tape around the cable (A). Start 2 in. [5 cm] below outer cable jacket and continue to taper at a point past the end of the lead wires (Fig 4).
- 2.4 **Generously** lubricate the cable 4 to 6 in. [10 to 15 cm] with supplied O-Ring grease.
- 2.5 Slide the cable boot components over the cable (A) in the following order (Fig. 4).
 1. Nut (D). Make sure threads are toward pump end of cable.
 2. Outer Cable Boot (C). Small end first.
 3. Inner Cable Boot (B). Small end first.
- 2.6 Remove tape and cut the lead wires back leaving about .50 in. [1.3 cm] exposed (Fig. 5).
- 2.7 Strip the inner conductor jacket .50 in. [1.3 cm] (Fig. 5).

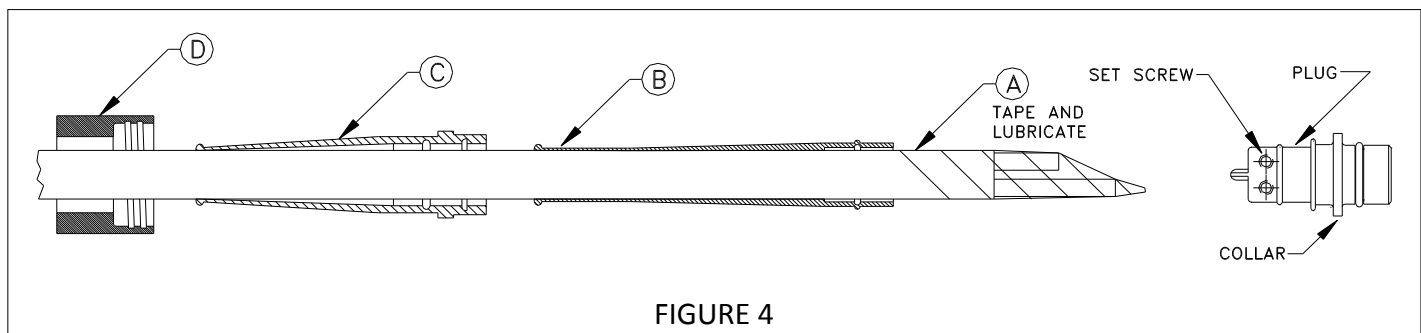
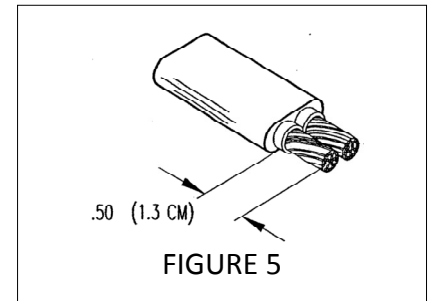
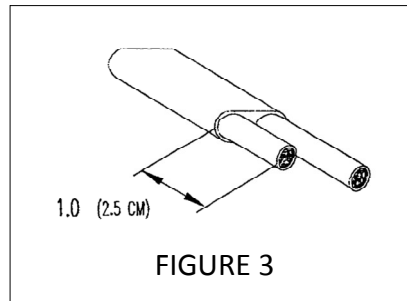
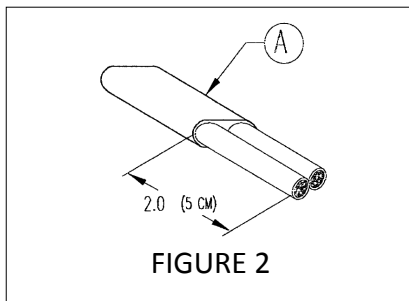

PUMP CONNECTION & INSTALLATION INSTRUCTIONS (Continued)

- 2.8 Insert the wire leads into Plug (Cable Adapter) connectors and use a 5/64" Allen Wrench to tighten the set screws (Fig. 6). Either wire can go into either plug hole. Pump performance will be the same.
- 2.9 Slide the Inner Cable Boot (B) over the plug until it is flush with the first step on the collar (Fig. 7).
- 2.10 Wipe the grease from the surface of the Inner Cable Boot (B) and Cable (A).
- 2.11 Tape end of Inner Cable Boot (B) tightly to the Cable (A). Tape 4 in. (10 cm) past the Inner Cable Boot (B) onto the Cable (A).

Note: This taped area allows the Outer Cable Boot (C) to slide freely over the Inner Cable Boot. **DO NOT REMOVE THE TAPE.**

- 2.12 Lubricate the outer surface of the Inner Cable Boot (B) and tape with supplied O-Ring grease.
- 2.13 Slide the Outer Cable Boot (C) over the Inner Cable Boot (B) until it is flush with the second step on the collar (Fig. 7).
- 2.14 Push the Plug (Cable Adapter) into the Receptacle (Cable Adapter) until the collar is seated flush.
- 2.15 Push the Nut (D) over the Plug (Cable Adapter) and then finger tighten the nut.

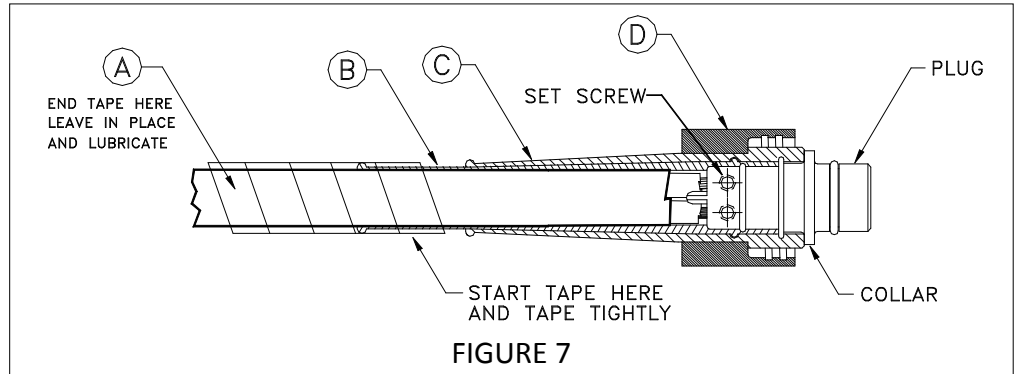
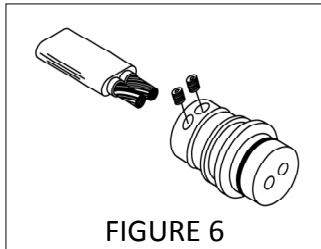

NOTE: Before continuing, operate the pump to check all electrical connections. Refer to Technical Specifications (Pg. 14). If the pump does not operate, refer to **TROUBLESHOOTING** (Page 8).

3. Install the 6 inch hose and fitting (1/2" NPT-M x 1/2" BARB) (Fig. 8)

- 3.1 Press the fitting into the 6 in. hose, slide a clamp on the hose and over the fitting and tighten the clamp securely.
- 3.2 Slide another clamp on the 6 in. hose and slide the assembly over the barbed fitting on the pump and tighten the clamp securely.

Note: Select the proper adapter hose and accessories for the pump.

USE OF DISCHARGE PIPE LARGER THAN 3/4" IS NOT RECOMMENDED..

Use 150 P.S.I. Min. [10 bar] working pressure rated 1/2 in. [13 mm] Inner Diameter smooth bore hose. Use included All-Stainless Steel hose clamps.

4. Hook-up Safety Line (Sling) (Fig. 8)

CAUTION: Safety line (Sling) should be Corrosion-resistant.

- 4.1 Insert safety line (Part not included) through lift plate holes.
- 4.2 Fasten line with appropriate connection approximately 1-2 ft [25-50 cm] above the pump.

5. Band the Hose, Safety Line, and Electrical Cable (Fig. 9)

- 5.1 Tie the drop lines together using tie wrap every 6ft. (1.8 m). This banding will prevent damage to the lines during Installation and Removal of pump.

6. Install Pump (Fig. 9).

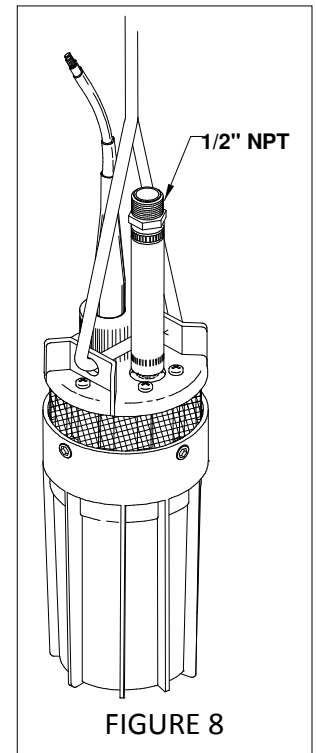

PUMP CONNECTION & INSTALLATION INSTRUCTIONS (Continued)

Notes:

Prior to installing the pump, fill in the Application Worksheet on page 3.

The Application Worksheet is a guide to make sure that the pump is installed properly in the well.

Following the guidelines laid out in the Application Worksheet will allow the pump to perform efficiently and extend the life of the unit.

Maximum pump submersion level below the static water level is 100 feet.

Refer to **TROUBLESHOOTING** on page 8 if you experience any difficulties.

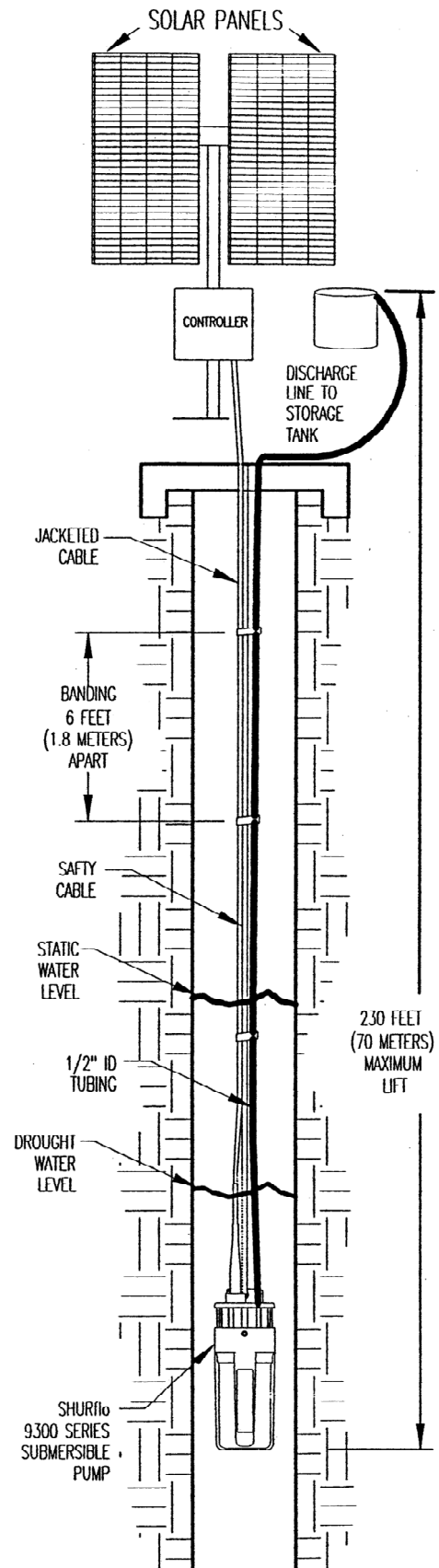

FIGURE 9

TROUBLESHOOTING

SYMPTOM

POSSIBLE CAUSE

CORRECTION

**PUMP OPERATES:
NO FLOW or
REDUCED FLOW**

1. LOW VOLTAGE

1. CHECK POWER SUPPLY FOR PROPER VOLTAGE.
REFER TO TECHNICAL SPECIFICATIONS

2. NO WATER AT PUMP

2. MAKE SURE THE PUMP IS INSTALLED
BELOW THE LOWEST ANTICIPATED WATER LEVEL
REFER TO INSTALLATION SECTION

3. PUMP LOCATED
TOO DEEP

3. REFER TO INSTALLATION SECTION
FOR PUMP OPERATING RANGE

4. CLOGGED FILTER SCREEN

4. REMOVE FILTER SCREEN AND RINSE
REFER TO REMOVAL AND DISASSEMBLY

5. FLUID PATH IN
PLUMBING RESTRICTED

5. CHECK FOR PINCHED HOSE and CLOGGED LINES

6. LOOSE CONNECTIONS
or PUNCTURED HOSE.

6. CHECK HOSE CLAMPS or REPLACE HOSE

**PUMP WILL
NOT OPERATE:**

1. INCORRECT POWER SUPPLY

1. CHECK POWER SUPPLY
REFER TO PUMP TECHNICAL SPECIFICATIONS

2. WIRE CONNECTIONS

2.1 CHECK ELECTRICAL CONNECTIONS ON
SYSTEM

2.2 CHECK THE CABLE PLUG ELECTRICAL CONNECTION
FOR CORROSION OR LOOSENESS
REFER TO CABLE BOOT INSTALLATION
INSTRUCTIONS FOR DISASSEMBLY
AND REASSEMBLY

2.3 CHECK FOR BLOWN FUSES IN-LINE

CONTACT AN AUTHORIZED DISTRIBUTOR FOR FURTHER ASSISTANCE

Go to www.shurflo.com for a list of SHURflo Solar Distributors

II. PUMP REMOVAL AND DISASSEMBLY

Warning: Make sure all electrical power is off and the Hose (Pipe) is not under pressure.

Warning: Canister may be pressurized. Disassemble the pump in proper order. Follow the directions carefully.

Note: Keep all of the parts clean after disassembly. Upper Housing Assembly contains small parts. Be careful not to lose parts after removing Upper Housing (N) in step 9.

1. Turn Off All Electrical Power

2. Remove the Pump from the Well

NOTE: To prevent damage to the Electrical Connection **DO NOT PULL ON THE ELECTRICAL CORD OR USE IT TO LIFT THE PUMP OUT OF THE WELL.**

3. Disconnect the Hose

- 3.1 Remove the Hose clamp.
- 3.2 Pull and twist the hose to remove it from the fitting.

4. Unplug the Cable Adapter Assembly (Fig 10)

- 4.1 Remove the Nut (D) unscrewing it counterclockwise and pull the plug up.

5. Remove the Lift Plate (F) (Fig. 10)

- 5.1 Use a #2 Phillips Screwdriver to remove 6 screws (E).
- 5.2 Pull up the Lift Plate (F).

Note: Be sure to put the O-Rings (I) back on the Lift Plate Posts (F). (Fig. 11, View B) before continuing to Step 6.

6. Remove the Filter Screen (M) for Cleaning

- 6.1 Slide the Filter Screen (M) out of the Canister (U).

6. Remove the Outlet Fitting (G) (Fig. 10)

- 6.1 Pull the Fitting (G) straight out from the Upper Housing (N).

7. Remove the Receptacle (Cable Adapter) (J) (Fig. 10)

Note: **DO NOT** PULL ON THE ELECTRICAL PRONGS.

- 7.1 Using pliers, **carefully** pull up on the shoulder of the Receptacle (Cable Adapter) (J).
- 7.2 Pull Cable Adapter (J) completely out of the Upper Housing (N).
- 7.3 Use a 5/64" Allen Wrench to loosen the 2 screws (K) holding the motor leads and disconnect the Receptacle (Cable Adapter) (J).

8. Remove the Canister (U) (Fig. 11)

- 8.1 Use a 3/16" Allen Wrench to remove the 3 screws (V).
- 8.2 Holding the Upper Housing (N) and the Canister (U), twist and pull the Assembly apart.

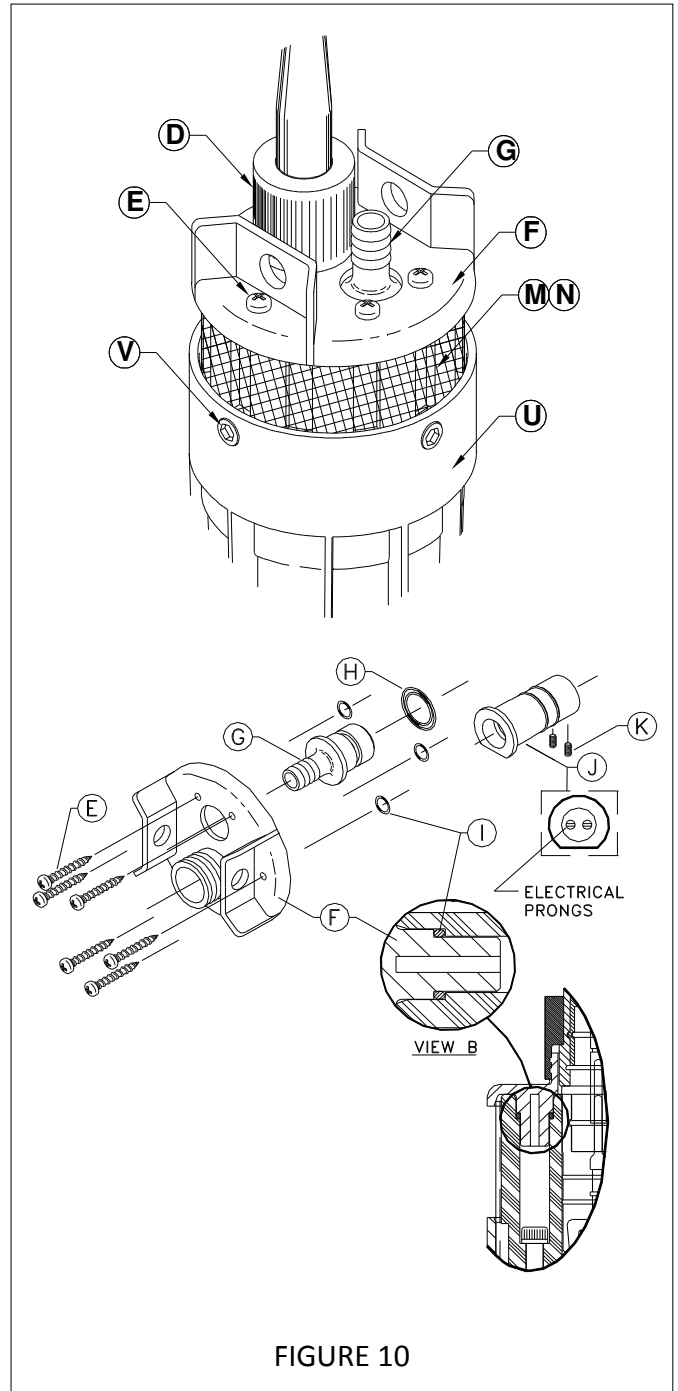

PUMP REMOVAL AND DISASSEMBLY (CONTINUED)

9. Remove Upper Housing (N) and Motor (T) (Fig. 11)

Note: Keep all parts clean after disassembly.
The Upper Housing Assembly contains small parts.
Be careful not to lose parts after removing Upper Housing.

- 9.1 Use a 5/32" Allen Wrench to remove the 3 screws (L).
- 9.2 Before separating the Upper Housing (N) from the Motor (T), place the assembly with the Upper Housing (N) down and the Motor (T) facing up.
- 9.3 Separate the Upper Housing (N), Valve Housing (R), Lower Housing (S), Poppets (Q), and Springs (P).

Contact an authorized distributor for assistance with diagnosis and replacement Parts.
Refer to page 15 for a Replacement Part Kit list.

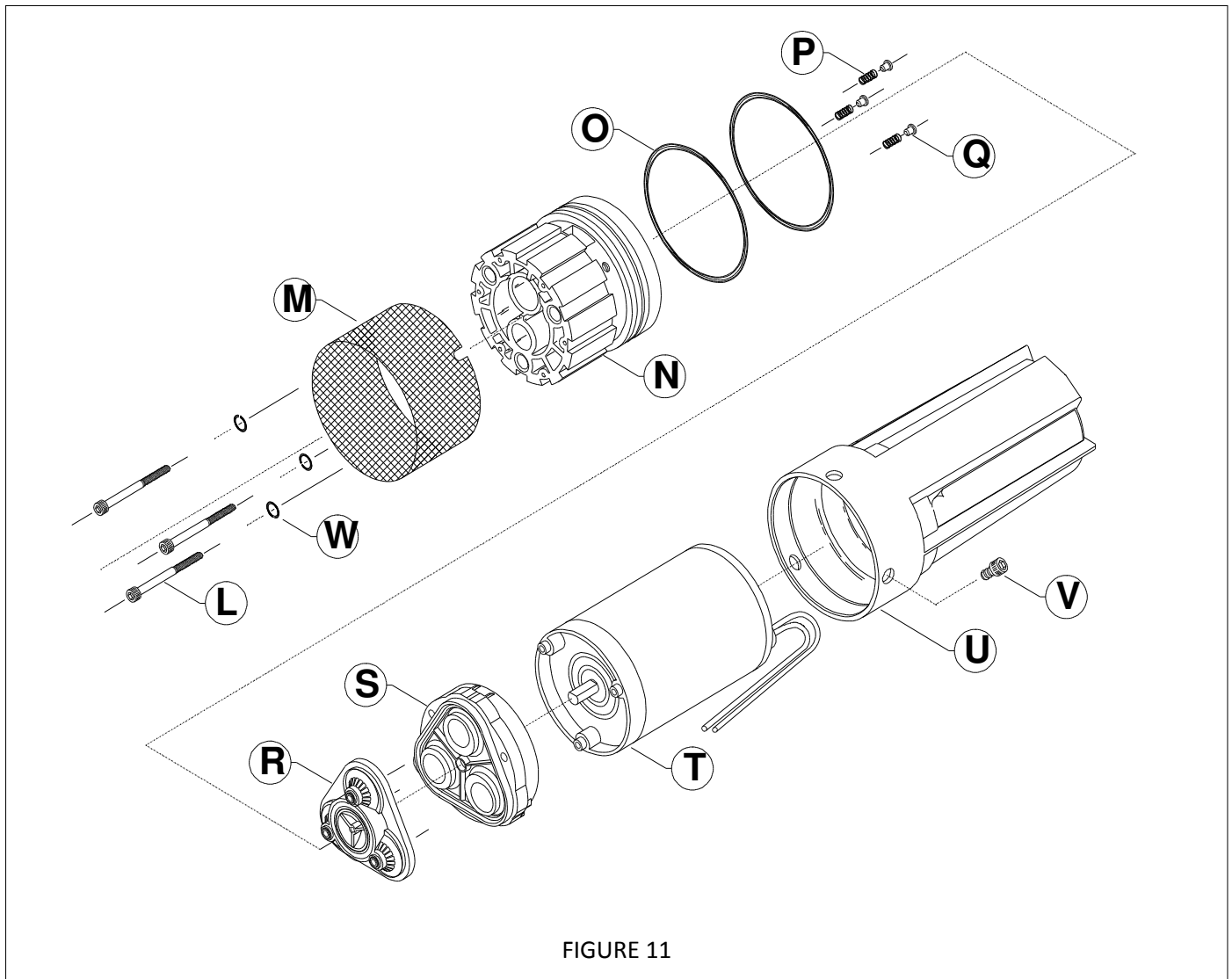

III. PUMP RE-ASSEMBLY

Warning The Order of Assembly is important for proper sealing.

1. Install the Upper Housing Large O-Rings (O) (Fig. 11 & 12)

- 1.1 Remove the existing Large O-Rings and thoroughly clean the O-Ring grooves with a dry cloth and a cotton tipped applicator.

Note: Lubricate the O-Rings with the Supplied O-Ring Grease. **DO NOT** USE PETROLEUM BASED LUBRICANT.

- 1.2 Slide the two new Large O-Rings over the Upper Housing (N) and into the O-Ring grooves.
1.3 Place the Upper Housing down with the internal cavities exposed. Turn the Upper Housing until the motor wire holes are directly in front.

2. Install the Bypass Assembly (P and Q) (Fig. 11 & 12)

- 2.1 Place the Poppets (Q) into the Springs (P).

Note: Make sure that the Poppets are seated flush against the Springs.

- 2.2 Locate the three bypass cavities and place the Spring/Poppet Assembly into the cavities with the Poppet up.

3. Install the Valve Housing Assembly (R) (Fig. 11 & 12)

- 3.1 Place the Valve Housing Assembly into the Upper Housing (Part N).

Note: Make sure that the inlet valves are centered on top of the bypass Poppets (Q).

4. Install the Lower Housing Assembly (Part S) (Fig. 11 & 12)

- 4.1 Place the Lower Housing Assembly onto the Valve Housing Assembly (R) (Fig. 12).

Note: **DO NOT** FORCE THE ASSEMBLY.

IT SHOULD SNAP TOGETHER EASILY IN ORDER TO SEAL PROPERLY.

5. Install the Motor (T) (Fig. 11 & 12)

- 5.1 Lubricate the motor shaft with a small amount of general purpose grease.
5.2 Align the "D" flat of the motor shaft with the "D" flat on the Lower Housing Assembly (S).
5.3 Align the motor lead wires with the Upper Housing (N) wire holes.
5.4 Align the three tabs on the motor (T) with the holes on the Lower Housing Assembly (S) and set the motor onto the Lower Housing.
5.5 Insert the motor lead wires into the Upper Housing motor wire holes.
5.6 Push the wires until they touch the surface that the Upper Housing is resting on.

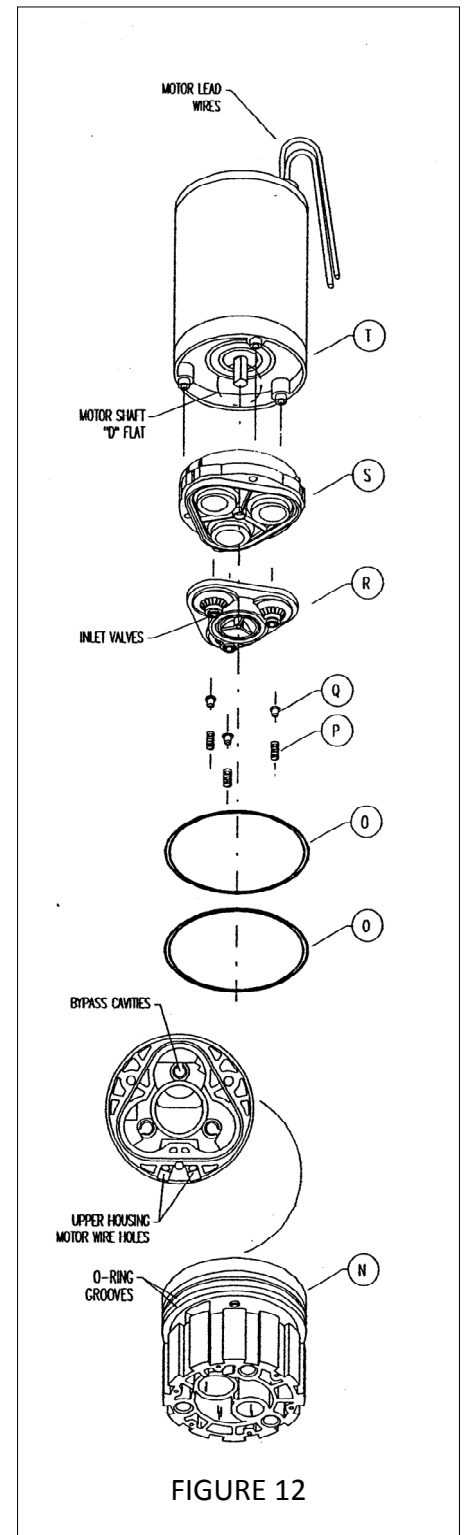

PUMP RE-ASSEMBLY (Continued)

6. Install the Canister (U) (Fig. 13)

- 6.1 Clean the inside of the Canister with a dry cloth.
- 6.2 Align the wire channel in the canister with the motor lead wires.
- 6.3 Slide the canister over the entire assembly.
- 6.4 Twist the canister to align the screw holes and carefully press on the bottom end to seat properly.

7. Install the Screws (V) (Fig. 13)

Note: **DO NOT USE MORE THAN 15 (± 5) in-lb [1.7 Nm (± .5)] TORQUE TO PREVENT STRIPPING.**

- 7.1 Using a 3/16" Allen Wrench tighten the screws in 3 places into the Upper Housing (N).

8. Turn the Assembly over as shown in Figure 14

9. Install the Lock Washers (Part W) and Screws (Part L) (Fig. 14)

- 9.1 Slide the three Lock Washers (W) onto the screws (L) and place the screws in 3 places into the Upper Housing (N).

Note: **DO NOT COMPLETELY TIGHTEN ONE SCREW AT A TIME. TIGHTEN THE SCREWS WITH TWO PASSES, SLOWLY COMPRESSING THE ASSEMBLY TOGETHER.**

- 9.2 Using a 5/32" Allen Wrench tighten the screws on the first pass with 25 (± 5) in-lb [2.8 Nm (± .5)] torque.
- 9.3 Tighten the screws on the second pass with 65 (± 5) in-lb [7.3 Nm (± .5)] torque.

10. Connect the Receptacle (Cable Adapter J) (Fig. 15)

Note: **The orientation of the motor lead wires will not affect pump performance.**

- 10.1 Pull the motor lead wires up through the Upper Housing (N) and insert them into the Receptacle (Cable Adapter J).
- 10.2 Using a 5/64" Allen Wrench hand tighten the screws on the Receptacle (Cable Adapter J) for both wires.

Note: **DO NOT TIGHTEN WITH A POWER TOOL.**

- 10.3 Lubricate the outer surface of the Receptacle (Cable Adapter J) with the supplied O-Ring grease.
- 10.4 Match the flat side of the Receptacle (Cable Adapter J) with the flat side of the hole in the Upper Housing (N).
- 10.5 Push the Receptacle (Cable Adapter J) into the hole in the Upper Housing (N) until it is seated flush.
- 10.6 Spread each Receptacle (Cable Adapter J) electrical prong slightly to insure a good electrical connection.

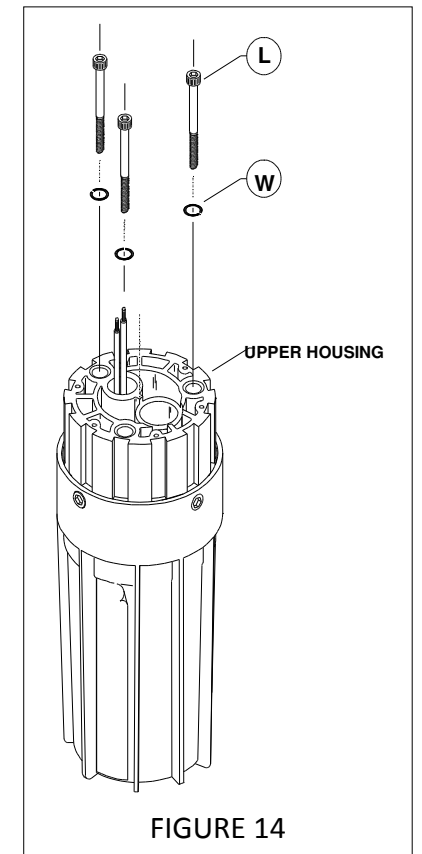
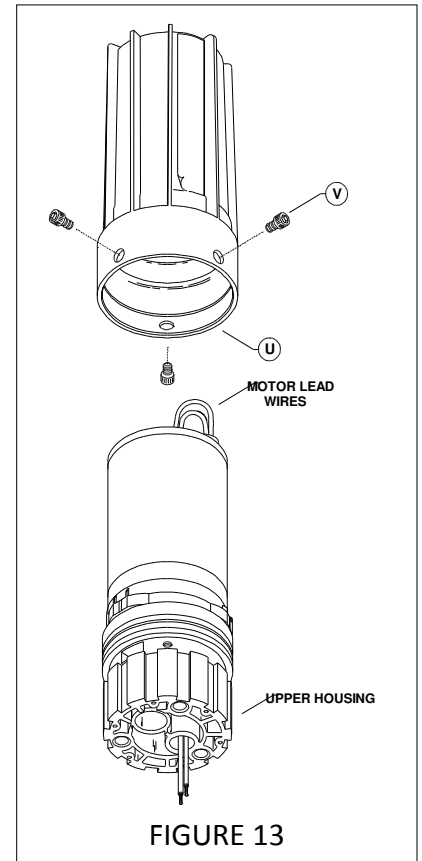

PUMP RE-ASSEMBLY (Continued)

11. Install the Filter Screen (M) (Fig. 16)

- 11.1 Slide the Filter Screen (M) onto the Upper Housing (N).
- 11.2 Align the slots in the Filter Screen (M) with the screws (V) in the Upper Housing (N) and slide the Filter Screen (M) over the screws (V).

12. Install the Outlet Fitting (G) (Fig. 16)

- 12.1 Lubricate the O-Ring (H) and slide it into the O-Ring groove on the Outlet Fitting (G).
- 12.2 Push the Outlet Fitting (G) into the hole in the Upper Housing (N).

13. Install the Lift Plate (F) with three the O-Rings (I) on the posts (Fig. 16)

- 13.1 Lubricate 3 O-Rings (I) and slide them on the Lift Plate (F) posts located on the bottom side of the Lift Plate (F).
- 13.2 Align the three posts with the Upper Housing (N) screw holes and press on the Lift Plate (F) until it is flush against the Upper Housing (N).

Note: **DO NOT** USE MORE THAN 20 (\pm 5) in-lb [2.25 Nm (\pm .5)] TORQUE TO PREVENT STRIPPING .

- 13.3 Using a #2 Phillips Screwdriver install the screws (E) 6 places into the Lift Plate (F).

14. Install the Plug (Cable Adapter) Assembly

Note: The orientation of the Plug (Cable Adapter J) will not affect performance.

Note: IF IT BECOMES NECESSARY TO REASSEMBLE THE PLUG ASSEMBLY, REFER TO PUMP CONNECTIONS & INSTALLATION INSTRUCTIONS.

- 14.1 Align the Plug connector holes with the electrical prongs in the Receptacle (J).
- 14.2 Push the Plug into the Receptacle (J) until the collar is seated flush.
- 14.3 Push the Nut (Part D) over the Plug (Cable Adapter) and finger tighten the nut.

Note: Before placing the pump back into the well, operate the pump to check all electrical connections using the correct power supply. Refer to Technical Specifications (Pg. 14).

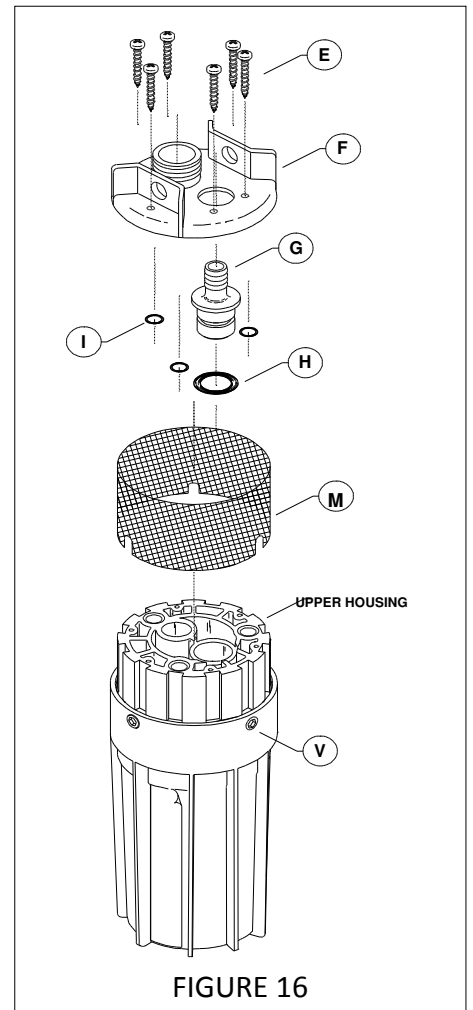
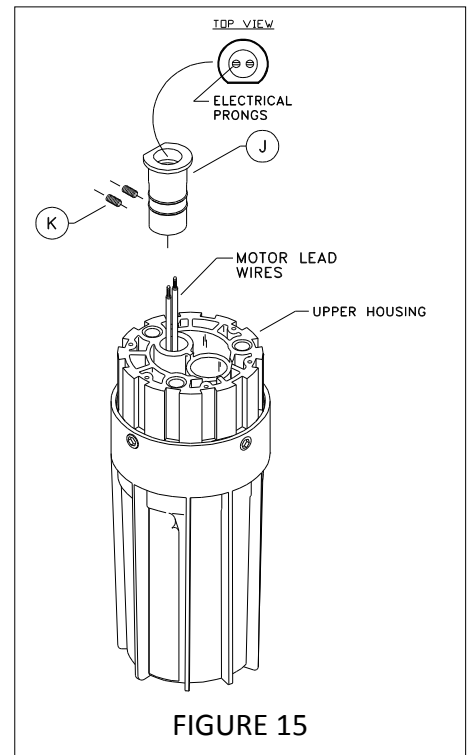

SPECIFICATIONS

| | |
|-------------------------|--|
| MODEL NUMBER: | 9325-043-101 |
| PUMP DESIGN: | Positive Displacement 3 Chamber Diaphragm Pump |
| CAM: | 3.0 Degree |
| MOTOR: | Permanent Magnet, P/N 11-175-00 Thermally protected |
| VOLTAGE: | 24 VDC Nominal (Reduced Volume @ 12VDC) |
| WATTS: | 120W |
| AMPS: | 4.0 MAX |
| FUSE: | 7.5 AMP (Automotive) Not Included |
| INTERNAL BYPASS: | 105-110 P.S.I. MAX (7.2-7.5 bars) |
| MAXIMUM LIFT: | 230 ft (70 M) |
| SUBMERSION: | 100ft (30 M) Maximum Below Waterline |
| OUTLET PORT: | 1/2" (13 mm) Barbed Fitting |
| INLET: | 50 Mesh Stainless Steel Screen |
| MATERIALS: | High Strength Plastics Stainless Steel Hardware |
| APPLICATION: | Potable water well pump |
| NET WEIGHT: | 6 lbs (2.72 kg) |

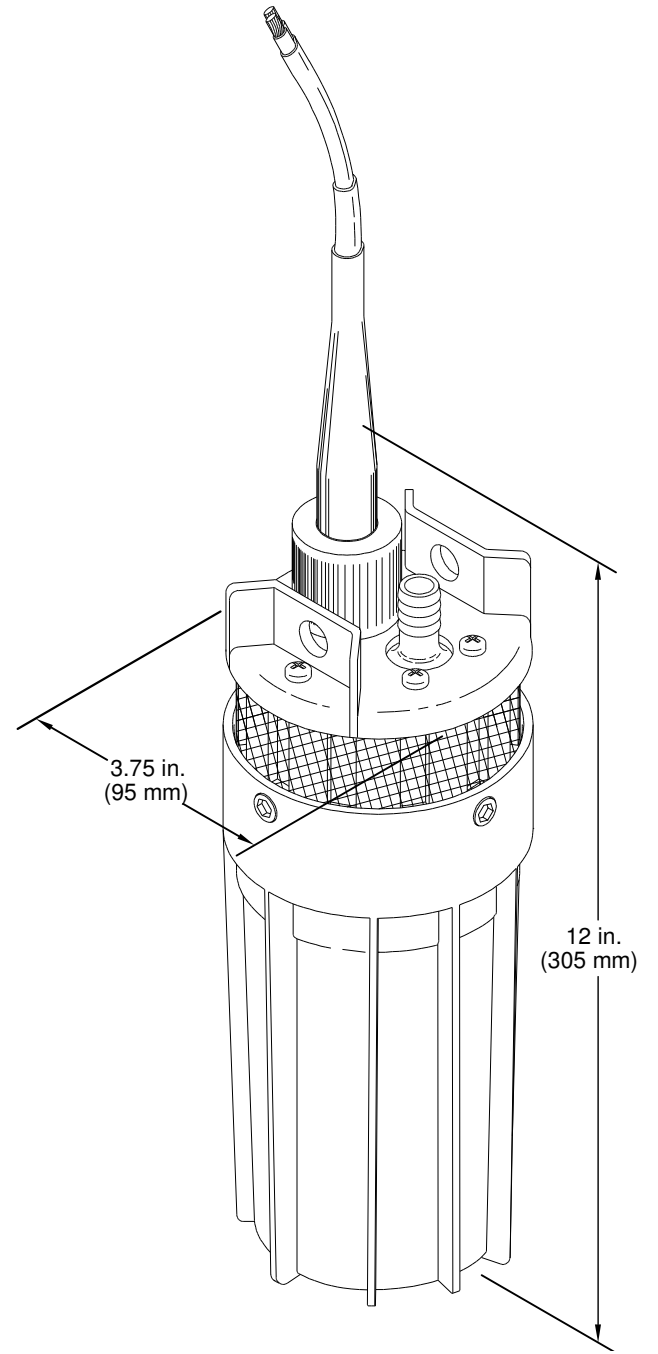

Design and specifications are subject to change without notice

NOTES: _____

MODEL 9325 SUBMERSIBLE PUMP PARTS LIST – Refer to FIGURE 17

| ITEM | DESCRIPTION | QUANTITY |
|-------------|----------------------------------|-----------------|
| A | CABLE [NOT INCLUDED] | 1 |
| B | INNER CABLE BOOT | 1 |
| C | OUTER CABLE BOOT | 1 |
| - | PLUG (CABLE ADAPTER) [NOT SHOWN] | 1 |
| - | SCREW (PLUG) [NOT SHOWN] | 2 |
| D | NUT | 1 |
| E | SCREW (LIFT PLATE) | 6 |
| F | LIFT PLATE | 1 |
| G | OUTLET FITTING | 1 |
| H | O-RING (OUTLET FITTING) | 1 |
| I | O-RING (LIFT PLATE) | 3 |
| J | RECEPTACLE (CABLE ADAPTER) | 1 |
| K | SET SCREW (RECEPTACLE) | 2 |
| L | SCREW (MOTOR) | 3 |
| M | FILTER SCREEN | 1 |
| N | UPPER HOUSING | 1 |
| O | O-RING (UPPER HOUSING) | 2 |
| P | SPRING (BYPASS) | 3 |
| Q | POPPET (BYPASS) | 3 |
| R | VALVE HOUSING ASSEMBLY | 1 |
| S | LOWER HOUSING ASSEMBLY | 1 |
| T | MOTOR | 1 |
| U | CANISTER | 1 |
| V | SCREW (CANISTER) | 3 |
| W | LOCK WASHER (MOTOR SCREW) | 3 |

REPLACEMENT PART KITS

| Model | Description | Contents |
|--------------|------------------------|---|
| 94-135-00 | LIFT PLATE | [E,F,I] |
| 94-136-00 | CABLE PLUG | [B,C,D,J,K,PLUG(CABLE ADAPTER) W/ SET SCREWS] |
| 94-137-00 | VALVE ASSEMBLY | [O,P,Q,R] |
| 94-138-00 | LOWER HOUSING ASSEMBLY | [O,S] |
| 94-139-00 | MOTOR | [O,T] |
| 94-140-00 | CANISTER | [O,U,V] |
| 94-141-00 | FILTER SCREEN | [M] |
| 94-142-00 | O-RING | [H,I,O,O-RING(VALUE HOUSING ASSEMBLY)] |

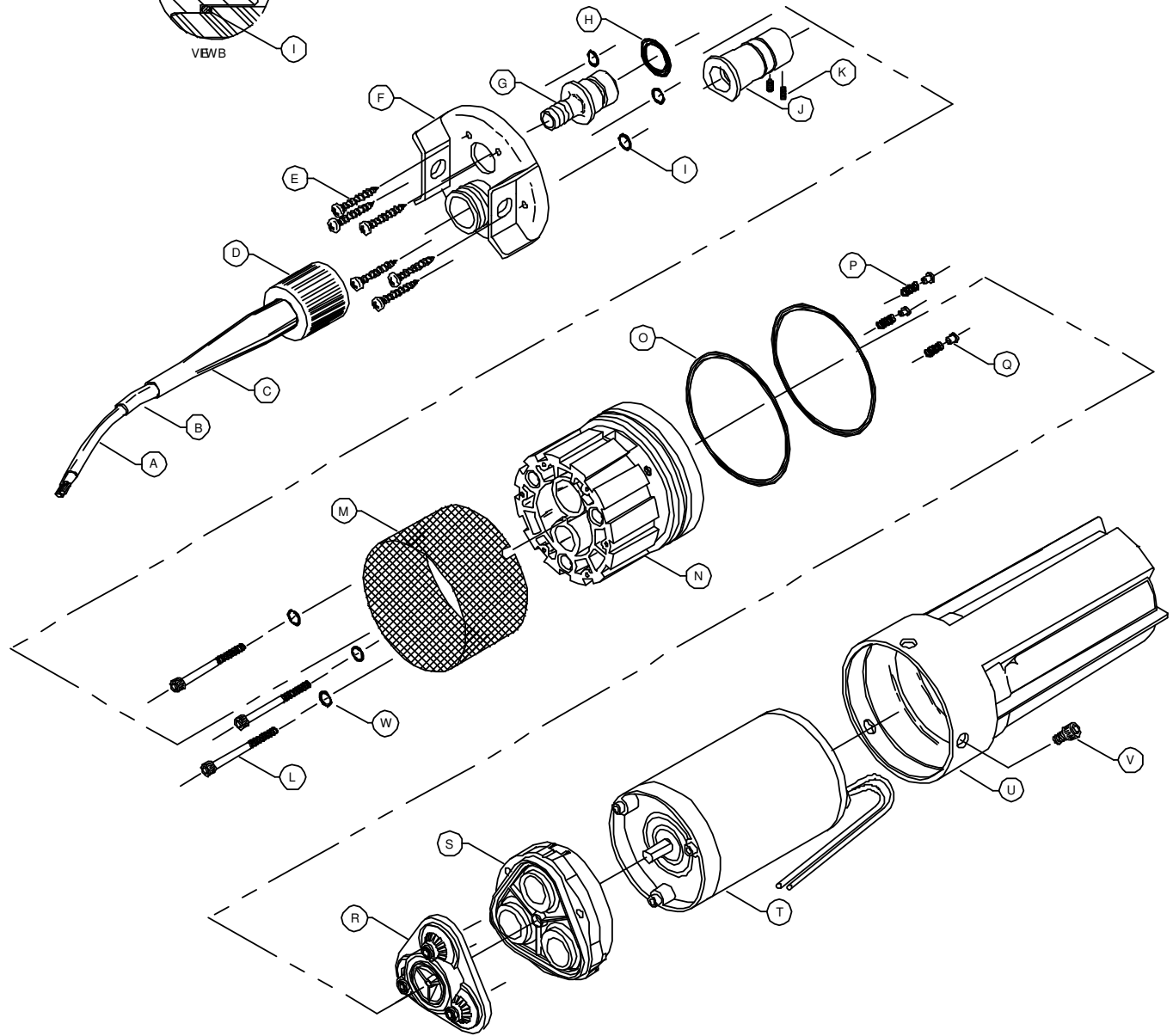
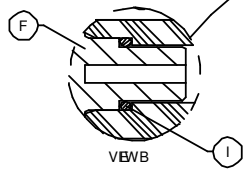
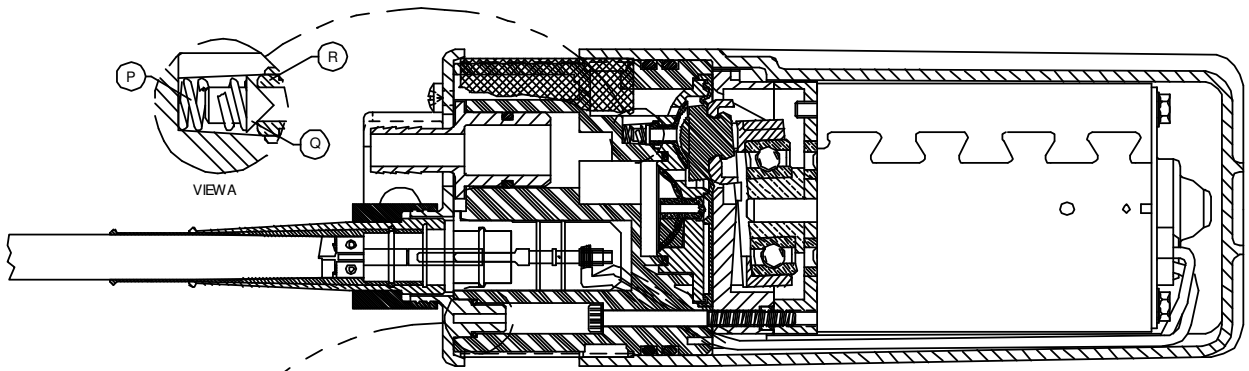

FIGURE 17

WARRANTY

LIMITED WARRANTY PROCEDURE

SHURflo warrants its pump to be free of defects in material and workmanship to the original retail purchaser for a period of one year beginning with the purchase date of the unit or, in the absence of proof of purchase date, one year from the date of manufacture as shown on the pump, not to exceed two (2) years in any event. Each pump has been operated and tested before being shipped from SHURflo's factory. During the warranty period if the pump is not operating correctly, you may return it freight pre-paid to your local distributor, dealer or directly to SHURflo.

Upon SHURflo's inspection, any unit found faulty due to manufacturing defects will be repaired or replaced at no charge. This warranty does not apply to any damage resulting from misuse, negligence, accidents, improper installation or wiring. Abuses such as removal of the SHURflo label, improper repair, installation, application, or damaged lower housing assembly due to running dry, are also not considered warrantable. There will be charges applied for any of the above mentioned non-warrantable items.

If you send the pump to us for repair, please package it carefully to avoid shipping damage. Enclose your name, address, a phone number where you may be reached and a copy of your proof of purchase.

The above represents our warranty policy. Under no circumstances will we assume or accept responsibility for unauthorized expenditures, losses, or any costs greater than the basic pump value.



SHURFLO

3545 Harbor Gateway South, Ste. 103, Costa Mesa, CA 92626, (800) 854-3218 www.shurflo.com

SHURFLO Europe, Middle East, Africa

Pentair Water Belgium bvba, Industriepark Wolfstee, Toekomstlaan 30, B-2200 Herentals, Belgium, +32-14-283500

All Pentair trademarks and logos are owned by Pentair, Inc. All other brand or product names are trademarks or registered marks of their respective owners.

Because we are continuously improving our products and services, Pentair reserves the right to change specifications without prior notice.

Pentair is an equal opportunity employer.

911-415 Rev L 06/12 ©Pentair, Inc. All rights Reserved.